



ALLOCATION PROCEDURES & DISPLAY GUIDELINES

EFFECTIVE January 6, 2020

The following Allocation Procedures and Display guidelines are provided to guide you in preparing for the show. NMMA will retain the right, at its sole discretion, to allocate exhibit space based on the best interest of each show. The seniority point system shall guide NMMA decisions, but is not the sole factor in determining exhibit space allocation. NMMA will interpret the procedures and guidelines in this booklet to produce the best possible show for all exhibitors.

NMMA Show Seniority Points and NMMA Membership Seniority Points

NMMA show seniority points are earned by an Exhibitor's participation in NMMA boat shows and trade shows. NMMA membership points are earned based on years of membership in NMMA. Both show seniority points and membership points are benefits extended to Exhibitors/Members by NMMA. These seniority points do not constitute property and are not assets owned by Exhibitors/Members. They may not be transferred to another Exhibitor without the approval of NMMA.

NMMA Canada members—both show seniority points and membership points are benefits extended to Exhibitors/Members by NMMA.

NMMA Consumer Boat Shows/Trade Events Allocation Procedures

Definition: An Exhibitor is an entity that purchases space in any NMMA boat show or trade event and has its own seniority "track" in show records. The Exhibitor may be a corporation, corporate subsidiary, person, partnership, organization, or other legal business. A Member-Exhibitor is such an entity, which currently holds rights of membership in the NMMA, either under its own name or as part of a larger entity.

1. Consumer Shows

All Exhibitors will be ranked in a Single-Tiered seniority list according to years of participation in a specific show. An exhibitor receives one point for each year it has exhibited in the particular show in question.

Single-Tiered allocation system is applied to the following shows:

Progressive[®] Insurance Atlanta Boat Show[®]
 Progressive[®] Insurance Atlantic City Boat Show[®]
 Progressive[®] Insurance Baltimore Boat Show[®]
 Progressive[®] Insurance Chicago Boat, RV & Strictly Sail Show[®]
 Progressive[®] Insurance Chicagoland Fishing, Travel and Outdoor Expo[®]
 Progressive[®] Insurance Kansas City Sportshow[®]
 Progressive[®] Insurance Louisville Boat, RV & Sportshow[®]
 Progressive[®] Insurance Miami International Boat Show[®]
 Progressive[®] Insurance Minneapolis Boat Show[®]
 Progressive[®] Insurance Nashville Boat Show[®]
 Progressive[®] Insurance New England Boat Show[®]
 Progressive[®] Insurance New York Boat Show[®]
 Progressive[®] Insurance Northwest Sportshow[®]
 Progressive[®] Insurance Norwalk Boat Show[®]
 Progressive[®] Insurance Saltwater Fishing Expo[®]
 Progressive[®] Insurance St. Louis Boat & Sportshow[®]
 Progressive[®] Insurance Tampa Boat Show[®]
 Progressive[®] Insurance World Fishing & Outdoor Exposition[®]

The order of priority for the allocation of available space in Single-Tiered shows is:

- a. First priority goes to Exhibitors that have exhibited in the prior year.
- b. Second priority goes to Members that have or have not previously exhibited and have submitted an application including payment at least 90 days prior to the show's opening.
- c. Third priority goes to Non-Member Exhibitors that have previously exhibited and have submitted an application including payment at least 90 days prior to the show's opening.
- d. Fourth Priority goes to Non-Members that have not previously exhibited.

NOTE: "Prior" in the above refers to the immediate preceding year; an Exhibitor who drops out keeps their points, but is not considered a "prior year" exhibitor when returning.

NOTE: *In the allocation phases of b) & c), space is allocated based on previous show history and the date the application and payment are received.*

NOTE: *In allocation phase d), space is allocated based on the date the application and payment are received.*

2. Progressive Insurance® Miami International Boat Show® & Strictly Sail and The International Boatbuilders' Exhibition & Conference® (IBEX)

All companies will be allocated space through a Double-Tiered seniority list, which is a combination of show points and Member points. An Exhibitor is awarded one point for each year it has exhibited in the particular show/trade event in question. Each Exhibitor receives one point for each consecutive year it has been a member of NMMA or either predecessor association – Boating Industry Association (BIA) or National Association of Engine and Boat Manufacturers (NAEBM).

The Double-Tiered allocation system is applied to the following shows/trade events:

Progressive® Insurance Miami International Boat Show® & Strictly Sail® and The International Boatbuilders' Exhibition & Conference® (IBEX)

The order of priority for the allocation of available space in Double-Tiered shows is:

- a. First priority goes to Member Exhibitors that have exhibited in the prior year.
- b. Second priority goes to Members that have or have not previously exhibited and have submitted an application including payment at least 90 days prior to the show's opening.
- c. Third priority goes to Non-Member Exhibitors that have exhibited in the prior year.
- d. Fourth priority goes to Non-Members that have or have not previously exhibited and have submitted an application including payment at least 90 days prior to the show's opening.

NOTE: *"Prior" in the above refers to the immediate preceding year; an Exhibitor who drops out keeps their show points but is not considered a "prior year" Exhibitor when returning.*

NOTE: *In the allocation phase b), space is allocated based on Member and show seniority combined. In allocation phase c), space is allocated based on total show point accumulation. In allocation phase d), space is allocated based on total show point accumulation and the date the application and payment is received.*

NOTE: *Space will not be allocated without the receipt of a signed application and payment.*

3. Additional Guidelines

- a. Exhibitors History (its seniority points), is the mainstay of the NMMA allocation system. Each Exhibitor will be awarded one show point for each year in which an Exhibitor exhibited at the show. An Exhibitor's Show History record will be carefully maintained by NMMA, and no trading of space, sharing of seniority points between commonly-owned entities, or other deviations will be permitted if the result, in the opinion of the NMMA is "leap frogging" by one Exhibitor over another with more points.

In the event that the Exhibitor shall cease conducting business in the normal course, become insolvent, make a general assignment for the benefit of creditors, suffer or permit the appointment of a receiver for its business or assets or shall avail itself of, or become subject to, any proceeding under the Federal Bankruptcy Act or any other statute of any state relating to insolvency or protection of rights of creditors ("Bankruptcy or Financial Reorganization"), then all show seniority points related to that Exhibitor or any Affiliates included in such actions are forfeited and may not be resurrected at a later date. Should Exhibitor, its Affiliates or its successor emerge from Bankruptcy or Financial Reorganization or other actions stated above at a later date and wishes to exhibit in an NMMA show, its seniority points begin at zero. Forfeited show seniority points will not be reinstated.

- b. Show Point Ties for renewing Exhibitors will be broken based on the following criteria:
 1. In the case of a point tie between two or more Exhibitors, priority shall be given to the Exhibitor with the highest average square footage of space at that particular show over the preceding three calendar years.
 2. If there is still a tie, the tie shall be broken based on consecutive years exhibited.
 3. If there is still a tie, priority shall be given to the exhibitor that has submitted its application and deposit on the earliest date.
- c. NMMA retains the right, at its discretion, to group like and related products, and to consider ceiling and door heights and other factors in planning exhibit areas in the best interest of each show. The seniority point system shall not interfere with such necessary management decisions.
- d. Exhibition at a show in consecutive years is not required to retain show points previously accumulated (provided that the Exhibitor is in compliance with all other guidelines outlined in the rules and regulations).
- e. The seniority point system shall be used for the purpose of upgrading Exhibitors to new locations within a show, and for the purpose of increasing the size of an Exhibitor's space, when such space becomes available for re-allocation among current

Exhibitors. Generally, no displacement of current, individual Exhibitors should occur. The seniority system will be “frozen” 90 days prior to the show. Applications and requests for changes received fewer than 90 days before the start of a show will be given priority based on the order in which they were received, without regard to membership or seniority.

- f. Some shows have NMMA Member Only designated areas. Check your contract back for these shows/areas.

4. Dealer/Manufacturer Allocation

1. Manufacturers Turning Space Over to Dealers

- a. In cases where a manufacturer contracts for the space, they may voluntarily turn the space over to their dealer, if the dealer has been the only such dealer in that space for the previous 2 years or more. In such cases show seniority points remain with the manufacturer and do not apply to future allocation for the dealer.
- b. In cases where a manufacturer contracts for the space and the space was worked by multiple dealers, the space may not be turned over. The space will be released and re-allocated according to the seniority point system. If the individual dealers wish to apply for space, their own seniority points will determine allocation of their space and they will be considered renewing Exhibitors.

- 2. In cases where a manufacturer loses their ability to exhibit in a space due to a change in boat lines carried at a dealership, and wishes to apply for space, their own show seniority points will determine allocation of space and they will be considered a renewing Exhibitor. In the event the show area is under the “freeze” policy, priority will be given to that manufacturer.

3. Dealers Turning Space Over to Manufacturers

- a. In cases where a dealer contracts for the space, they may voluntarily turn the space over to their manufacturer, if the manufacturer has been the only manufacturer represented by the dealer in that space for the previous 2 years or more. In such cases show seniority points remain with the dealer and do not apply to future allocation for the manufacturer.
- b. In cases where a dealer contracts for space and that space was occupied by multiple manufacturers, that space may not be turned over. The space will be released and re-allocated according to the seniority point system. If one of the represented manufacturers wishes to apply for space, their own seniority points will determine their allocation of space and they will be considered renewing Exhibitors.

5. Space “Freeze” Policy

- a. When a **show** has a higher demand for space than is available, 50% of all available space will be offered to existing Exhibitors that have requested an increase. The remaining 50% of available space will be offered to new companies that wish to exhibit in the show and have submitted an application and payment. Space will be allocated as described below in section 5b.
- b. When an **area of a show** has a higher demand for space than is available, a space “freeze” policy will be imposed. When a “freeze” policy is imposed:
 - i. Available space will be divided equally—50% will be allocated to those Exhibitors already in the “frozen” show or areas requesting a space increase and 50% will be allocated to those wishing to get in from the non-frozen areas.
 - ii. Exhibitors being allocated new or additional space in a “frozen” show or area will receive no more than: 100 sq. ft. if a booth; 400 sq. ft. if linear bulk space; 1,500 – 2,000 sq. ft. if bulk; or 2 slips if in-water. Minor increases or decreases in space due to a change in location will not be considered when applying the space “freeze” policy.
 - iii. Exhibitors in the “frozen” show or area will be eligible for a space increase (provided space is available) only after waiting at least four years after first entering the “frozen” area. Example: Exhibitor enters the “frozen” area in 2011, sits out 2012, 2013, 2014 and 2015 and is eligible in 2016.
 - iv. A maximum total space size cap may apply in shows that are “frozen” or have “frozen” areas.

6. Purchase of an Exhibitor Other Than Through or Out of Bankruptcy or Financial Reorganization

In cases where one company (the “Purchaser”) buys the assets of a qualifying company (the “Seller”), the following criteria will be used to determine transfer (if any) of the NMMA show seniority points, Member points, and/or existing boat show space by the Seller. If an Exhibiting company does not purchase space in any NMMA show and has not been an NMMA member in good standing for five consecutive years, it will be considered inactive, all show seniority points will be forfeited and its ability to transfer show seniority points to a new owner shall terminate. Upon notification to NMMA, Purchaser and Seller will be provided with documents needed to substantiate the transfer of any seniority points or boat show space.

Seller will complete a “Certificate of Sale” document. This document will initiate the internal process and NMMA staff will notify Purchaser of options in a timely manner. Purchaser can only exhibit newly purchased brands in existing boat show spaces once all documentation has been provided. For purposes of this section the following definitions will apply:

QUALIFYING COMPANY is a company that (i) is operating its business as a going concern at the time of the proposed sale or during the twelve months preceding the sale and has not been subject to or emerged from Bankruptcy or Financial Reorganization as defined in section 3(a), (ii) if applicable, is current in its dues payment to NMMA, (iii) has purchased or occupied space in any NMMA show at any time during the five-year period preceding the proposed sale, and (iv) is not in default in payment of any past due balance to NMMA at the time of the proposed sale.

SUBSTANTIALLY ALL OF THE ASSETS – A sale of substantially all of the assets of a company means the complete and final disposition of all or substantially all of the assets that a company had at the time it last participated in an NMMA show.

- a. The show seniority points cannot be sold, sublet, given, assigned, or otherwise transferred by a company, voluntarily or involuntarily. The show seniority points can only be transferred by a Qualifying Company as part of the sale of all or substantially all of its assets to the Purchaser and must be approved by NMMA.
- b. In the event substantially all of the assets of the Seller are sold, then, if the Seller's separate space is eliminated and absorbed into the Purchaser's, the seniority points of the Seller are liquidated and cannot be revived at a later date.
- c. When the buyer and seller have seniority point history, the new point total of the Purchaser will be determined by the total years either company accumulated points, but no year will be counted twice.
- d. All show seniority points are tied to one of the three types of manufacturing Members (boats, engines or accessories) and may not be transferred from one type of Member to another. If a Seller is a different type of Member, then a separate membership must be maintained by the Seller in order to exhibit the product of the Purchaser as a Member. In such cases, points and space are not transferable to the other type of membership. The exception to this rule is a corporate merge/display.
- e. When an Exhibitor files for or becomes subject to Bankruptcy or Financial Reorganization as defined in section 3(a), all show seniority points related to that Exhibitor or any Affiliates included in such Bankruptcy or Financial Reorganization are forfeited and may not be resurrected at a later date. If the Exhibitor, its Affiliates or its successor emerges from Bankruptcy or Financial Reorganization protection at a later date, the forfeited seniority points will not be reinstated.

7. International Companies

- a. Importers of boats and marine products are eligible to join NMMA as the exclusive U.S. representative of a particular international manufacturer, or as a general importing agent as an Association Member. However, such importers must have an individual membership in NMMA for each line represented if the particular

line is to receive Member treatment at boat shows or trade events. Members joining as "Representatives" or "Importing Agents" cannot use that membership to apply to one or more imported product lines.

- b. If a country has a group exhibit in an NMMA show or trade event, then the individual exhibitor within this group has the right to accumulate points, which will be considered if and when that company decides to have a separate exhibit of its own.

8. Member Companies

- a. Any Member is generally entitled to apply for show space, and not be rejected because of its product line. The exception to this would be semi-related product (this type of product has an application to not only the marine industry but to other industries: cars, homes, etc.) where the maximum allowable amount has already been met for that product. The reverse is not true; not all Exhibitors are eligible for membership.
- b. All Member Exhibitors including Associate Members enjoy Member space rates and seniority points. A Member-Exhibitor may display products for which it is not the Member (i.e., it is a dealer, distributor, or otherwise represents the product being displayed). However, if the exhibit is a single booth (10' x 10' booth or smaller), such space cost will be charged at the Non-Member rate; if larger, space cost will be pro-rated according to the amount of Member/Non-Member product, with a minimum billable space at 75 sq. ft. for each category. In such cases Member allocation priority, seniority, and space rate do not apply to exhibit space not occupied by the Member's own products or services.
- c. Entities owned by a "Parent" Member company which make a product pertaining to a different type of NMMA membership, are not entitled to the membership benefits or seniority of the Parent in show matters. (Example: a boat company begins to market a new line of electronics and wants a show space. The new product line/entity starts out with no points and must take separate membership to begin to accumulate Member points.) The exception to this rule is a corporate merge/display.
- d. Members are entitled to the Member-rate for space only if dues are paid prior to December 1st. New Members that join NMMA between the dues deadline and opening day of the show will receive a full Member discount. Exhibitor-Members dropping membership lose their Member benefits. Points accumulated by them during their membership will not be considered when allocating space. These Member points will be maintained as history and will be reinstated only if membership is reinstated within six months.

9. Common Ownership of Several Exhibitors

An Exhibitor can create or absorb into its display any number of "Brands." A Brand is meant to include any company product line, operating division or subsidiary; the relationship is not the governing

factor. The governing factor is that an Exhibitor is created or eliminated for a brand having a separate identity but owned by a parent company.

- a. A joint venture, whether between Members or between a Member and a non-member, is a separate company and does not qualify to use the Member status of either party.
- b. Dues payments from a Member company must include the applicable dues based on sales, for all brands it owns which purchase or expect to purchase space at NMMA shows/trade events at the Member space rate. Thus, Entity A, if it makes one payment to cover dues of all a parent's Member brands, must cover the dues applicable to those brands, if those brands are to enjoy Member benefits at shows.
- c. When an Exhibitor requests separate space for a new brand which has a separate identity, or takes an existing brand and decides it should have a space of its own, that brand becomes an Exhibitor, begins its own show points from zero and will not be treated as a prior year Exhibitor. For Double-Tiered shows, the brand is attached to the Member record, but with its own Member points starting at zero.
- d. When a parent company takes a brand which is already exhibiting separately and eliminates that brand or absorbs it into the parent's exhibit, the parent has the right to take over the space, but cannot transfer it to another brand. In such cases the show points are merged and cannot be revived at a later date. A new show point total will be determined by the total years either company accumulated points, but no year will be counted twice. In a Double-Tiered show, a new Member point total will also be determined.

In a show, if, after eliminating or absorbing a brand into the parent companies' exhibit, the parent should ever decide to separate again or sell off a brand, that brand would start its seniority at zero.

- e. In a show, Member points can go to both the Member of record and its separate brands each year. Show points go only to the individual Exhibitor of record and are specific to each show.
- f. Once a brand has established its own exhibit space, all allocation procedures apply to that Exhibitor on the same basis as with every other Exhibitor.
- g. An Exhibitor may in its space, present a "sampling" of other products made by entities which share common ownership under these guidelines:
 - i. Total space taken up by such "sampled" products may not exceed 20 percent of the total exhibit space.
 - ii. Only "static" displays of the sampled products may be displayed in the designated exhibit area.

- iii. Boats displayed as "samples" must have their own exhibit space in the same show.
- iv. The above applies to boats, engines, accessories, equipment, and services, but excepted are accessories, engines, and trailers which are integral to and part of a boat display in a boat area, and "slave" items, including logo'd merchandise. The intent of this rule is to demonstrate the diversity of a company's product lines, but not to add additional sales space for those sampled products.

10. Display Props

An exhibitor may exhibit products marketed by another manufacturer as a display prop such as an engine company using another company's boats to display engines at an in-water setting. Exhibitor will not display any product without the endorsement or approval of the manufacturer. However, exhibitor must have purchased exhibit space under its name in the same show.

11. Corporate Displays/Brand Consolidation for Exhibit Purposes

Corporate Display refers to a company whose manufacturer's different products in different NMMA divisions.

Brand Consolidation refers to a company that manufacturers different products in the same NMMA divisions.

A parent company may choose to combine all of its brands into a corporate display with one seniority total.

- a. In a brand consolidation, a company may have as many brands of the parent company within its space(s) as it determines necessary based on the parents' marketing plan.
- b. Brands may change from year to year and from show to show.
- c. Once the individual brand seniority has been absorbed, it cannot be resurrected in the future.
- d. Should the parent company ever decide to separate again or sell that brand, that brand's seniority would start at zero.

These rules apply to newly acquired brands as well as startup brands.

12. Compliance with U.S. Laws

Exhibitor represents and warrants that all displayed products comply with all applicable U.S. laws, regulations and consent decree or other mandatory requirements, including any applicable safety standards that may be issued by the Consumer Product Safety Commission (CPSC), and the emission regulations issued by the U.S. Environmental Protection Agency (EPA) (collectively the "Full Compliance Representation"). Enforcement officials from the U.S. EPA and other governmental agencies (potentially including U.S. Customs) will routinely inspect products at the show.

If applicable products do not meet the CPSC safety standard or EPA emissions compliance, they may not be displayed in any NMMA show. Exhibitors agree to cooperate fully with and respond to any questions from any government officials at the show. Exhibitors agree that neither the show parties (as defined in the exhibitor space contract) nor the show is responsible for the enforcement of emissions or safety regulations; and that none of the show parties nor the show may be held responsible for any penalties, burdens or costs that are associated with or result from the enforcement of environmental or safety laws by appropriate officials.

13. No False or Misleading Statements

Exhibitors represent and warrant that (in and around the show facility) they will not make any false or misleading statements or claims in print, orally, or in any medium about their or a competitor's products (collectively the "Truthful Advertising Representation"). For example, exhibitors will not advertise displayed products as being "EPA compliant" or "meeting EPA standards" if these products have not been certified to meet the current, applicable EPA control of emissions for propulsion marine engines and vessel standards.

14. Infringement

Exhibitor represents and warrants that any products or equipment which it exhibits in the show: (i) are and will be original with exhibitor and will not incorporate any ideas, concepts, techniques, inventions, creations, works, processes, designs or methods that are owned by or licensed exclusively to any third party, and (ii) do not and will not infringe upon or violate any patents, copyrights, trade secrets, trademarks or inventions or any other intellectual marketing rights of any third party (collectively, the "Infringement Representation").

15. Individual Exhibitors are Responsible for Enforcement

Exhibitors (not the show parties or the show) are responsible for enforcing (through the appropriate governmental or authorized officials) any claims against other exhibitors who are displaying products that allegedly violate their "Truthful Advertising Representation" (as set forth above in item #13 or their "infringement Representation" as set forth in item #14). For example, to remove an infringing product, an empowered government official should present a court-order that clearly and directly applies to the displayed, infringing product. However, exhibitors recognize and agree that the show (in its sole discretion) can require a manufacturer to remove from the show floor products that clearly and blatantly violate and breach the "Infringement Representation" as set forth in item #12 above.

16. Conduct Between Exhibitors

Exhibitors agree that they will not disrupt the show by harassing other exhibitors, or by disrupting other exhibitors' ability to conduct normal business activity at the show. In its sole discretion, NMMA may

physically remove from the exhibitor's booth space any person who is engaged in threatening, disruptive, or offensive behavior.

17. Rules and Regulations

NMMA shall have the power to adopt, amend, interpret, and enforce all show terms, rules and regulations with respect to the operation and conduct of the Show, including but not limited to those regarding the kind, nature, and eligibility of all exhibitors and exhibits at the Show and the marketing activities of exhibitors with respect to the Show.

18. Non-Current Product/Boats

Boat exhibitors may display up to 20% of new and unused previous model year boats in their display. A new boat is defined as a boat that has not been registered with the State.

Display Guidelines

These guidelines and regulations are intended to provide a basis for the building and construction of exhibits at all NMMA Boat Shows. We encourage exhibitors to submit proposals for exciting and dynamic display ideas that may seem "outside the box" directly to NMMA for approval. Each facility that houses our shows has specific rules that we, as tenants of the building(s), must adhere to. Please refer to the back of your show contract and your exhibitor kit for show specific guidelines. Each show manager is aware of the rules for the specific shows they manage and can therefore determine if your display suggestion meets these rules.

All bulk/open area exhibitors or anyone planning a newly constructed, elaborate display must submit a to-scale drawing of their exhibit to NMMA for approval. Please advise us if your exhibit has not been altered since last year; you may not need to reapply for approval.

Drawings need not be professionally done, but should show a "birds-eye view" and an elevation of your exhibit area. Be sure to indicate the heights and widths of both product and display materials as well as other appropriate dimensions or placements of equipment.

This drawing should be submitted no later than 60 days prior to show opening.

Any variance to accommodate creativity or uniqueness of an exhibit must first be approved by NMMA. Product placement, although subject to NMMA review and approval, is not bound by the following configuration guidelines. Should you have any questions about these limitations or positioning of product, please do not hesitate to contact NMMA.

A. Installation:

1. Specific instructions regarding loading in/out (i.e., dates, times, and directions, etc.) will be sent to each exhibitor, and must be strictly observed. Exhibitors will be billed for extra rigging services required because of delays caused by unprepared exhibits, including carpet installation, lack of appropriate cradling equipment, etc.; lateness; or any special/unusual handling of boats or equipment. Late exhibitors

arriving after their scheduled installation time can be relocated to any location specified by NMMA or, if no alternative is available may forfeit their show participation rights.

2. Exhibitors are required to comply with all labor practices and union agreements in effect at the show site.
3. Any equipment, signs or display units provided by the show will not become the property of the exhibitor.
4. No signs, walls, product, or any part of a display shall be set up so as to block off or otherwise interfere with the view of any other display. Exhibits are limited to the space provided in the contract. Product, personnel and/or display material may not extend into the aisles or adjoining space (including trailer tongues, wheels, stairs, stern drives, display/literature racks, etc.).
5. At some shows, all indoor exhibits must be carpeted. Check your contract or call NMMA for clarification.
6. Products may be suspended from the ceiling in some shows; however, permission of the show facility and NMMA must be received in writing prior to show move-in.
7. Boats may be stacked, nested, stood erect or on end only with prior NMMA approval.
8. Cradles must arrive pre-assembled. Any boats, which, in the opinion of NMMA, have unacceptable cradling/boarding equipment, will not be handled. Boats may be exhibited on trailers, cradles, jacks, dollies, wood blocks or cradles with wheels; on Styrofoam blocks with advance NMMA approval; but cinder blocks or any other modular blocking will not be allowed.
9. Boats less than 26 feet must have dollies or cradles with wheels to be handled by NMMA.
10. No damage of any nature may be done to booth structures or to any part of the exhibit hall or show grounds. Exhibitors will be held responsible for damages. No signs may be placed on columns or walls except within exhibitor's space (building regulations permitting). No nails or screws may be driven into the floor. Exhibitors are responsible for filling holes from tent stakes or from other structures not provided by NMMA, for removing tape from floors, and for removing carpet, including whatever's used to secure it.
11. No exhibitor may bring into the show any explosives, flares, gasoline, kerosene, acetone, LPG or other flammable or combustibles. No fuel may be stored in containers, boats, RV's, or authorized vehicles. All gas tanks must have locking gas caps or be taped closed. Batteries must be disconnected from ignition systems.

B. Construction:

1. All structures must conform to local fire, safety and building codes, and are subject to inspection. Ramps, platforms, and stairs must have adequate handrails. All exhibit structures or components in excess of 12'0" must have drawings available for inspection by NMMA, facility management, the installation and dismantling contractor and/or governmental authority before and during the time display is being erected, exhibited or dismantled at the show site. These drawings should include a signature or stamp of a reviewing structural engineer indicating that the structure design is properly engineered for its proposed use, and a signature is built in compliance with the details and specifications set forth on the drawings.
2. All decorations or building materials must be flameproof, and an affidavit or certificate evidencing such flame proofing must be available for potential inspection by Fire Department representatives. Open flames of any sort are prohibited.
3. All electrical wiring and equipment must meet appropriate municipal/governmental electrical codes.
4. Exhibitors are required to finish and decorate any unfinished partitions, walls or backs of signs, which are visible to the public. Two-sided identification signs along the back wall of an exhibit that detract from the adjoining exhibit must be removed or covered up. Exposed exhibit back walls will be draped or finished at exhibitor's expense.

C. Standard Booth Exhibits:

One or more standard units (10' x 10', 10' x 9', etc.) in a straight line.

Height: Exhibit fixtures and components will be permitted to a maximum height of 8'0", plus 2'0" for back wall identification signs—overall acceptable height is ten feet (building construction permitting). Sidewalls may extend 4'0" or 1/3 the depth (whichever is greater) from the back line at a height of 8'0", but then must drop to a 4'0" height.

Depth: All display fixtures over 4'0" in height and placed within 10 lineal feet of an adjoining exhibit, must be confined to that area of the exhibitor's space that is within '0" of the back line (towers included).

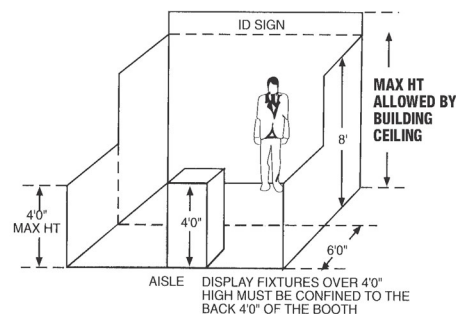

D. Perimeter Wall Exhibits:

Standard booth or bulk exhibits located on the outer perimeter wall of the exhibit floor.

Height: Exhibit back walls may rise continuously to a maximum height permitted by building ceiling(s), (with NMMA approval) but nothing may be attached directly to walls.

Depth: All display fixtures over 4'0" in height and placed within 10 lineal feet of an adjoining exhibit, must be confined to that area of the exhibitor's space that is within 4'0" of the black line (towers included).

E. Peninsula:

An exhibit space open on three sides that has a neighboring exhibitor or wall on the fourth side.

Height: Exhibit fixtures, components and identification signs will be permitted along the following guidelines (hall construction and space size permitting):

No wall/walled structure may be positioned along space edge. Any walls must be set at least 10'0" from any aisle(s).

Display fixtures placed within 10 lineal feet of an adjoining aisle must not exceed 4'0" in height. Display fixtures placed within 20 lineal feet of an adjoining aisle must not exceed 8'0" in height. Display fixtures placed more than 20 lineal feet from an adjoining aisle must not exceed 16'0" in height.

In PENINSULAS, back wall structures (hard wall or drapery) will be permitted with NMMA approval; but, must afford 10'0" of unobstructed view on either side of the exhibit/wall. Any variance requires the mutual (written) agreement of the exhibitors sharing the common line, and is subject to annual review of both parties and NMMA. It is also each exhibitor's responsibility to drape or finish exposed/unfinished portions of back wall(s).

NOTE: This rule may be waived by NMMA in certain cases where the back wall is on the perimeter of the display area (advance approval required).

PENINSULA

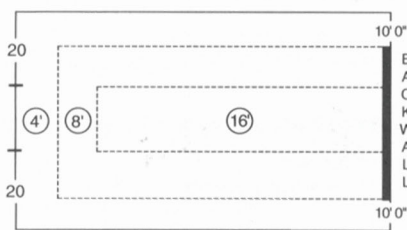

PENINSULA

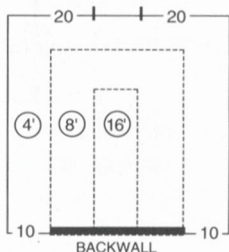

F. Island Exhibits:

An island exhibit is a space that is open on all four sides.

Height: Exhibit fixtures, components and identification signs will be permitted along the following guidelines (hall construction and space size permitting):

Display fixtures placed within 10 lineal feet of an adjoining aisle must not exceed 4'0" in height. Display fixtures placed within 20 lineal feet of an adjoining aisle must not exceed 8'0" in height. Display fixtures placed more than 20 lineal feet from an adjoining aisle must not exceed 16'0" in height.

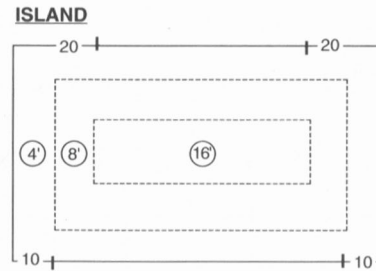

In MULTI-STORY EXHIBITS, regardless of whether people will occupy the upper area or not, the exhibitor must have drawings available for submission to NMMA, the installation and dismantling contractor, and governmental authority during the time the exhibit is being erected, exhibited and dismantled at the show site that include a signature or stamp of a reviewing structural engineering indicating that the structure design is properly engineered for its proposed use. Also required is a signature of an authorized official of the exhibit building company indicating that the structure is built in compliance with the details and specifications set forth on the drawing. Signs must also be posted indicating the maximum number of people the structure will accommodate.

NOTE: Peninsula booths are normally "faced" towards the cross aisle. Any "backside" portion of the exhibitor's booth that is visible must be finished at the exhibitor's expense and must not carry identification signs or other copy that would detract from the adjoining exhibit.

Exhibitors are cautioned when installing a display with a ceiling or second level to check with the local fire department to insure that their display meets with the necessary fire safety precautions involving smoke alarms, fire extinguishers, sprinkler systems, etc.

G. Linear Bulk Exhibits:

One or more oversized units (20' x 20', 25' x 30', etc.) in a straight line.

Height: Exhibit fixtures, components and identification signs will be permitted along the following guidelines (hall construction and space size permitting): No wall/walled structure may be positioned along space edge. Any walls must be set at least 10'0" from any aisle(s). Display fixtures placed within 10 lineal feet of an adjoining aisle must

not exceed 4'0" in height. Display fixtures placed more than 10 lineal feet from an adjoining aisle must not exceed 8'0" in height (with the exception of towers). Double-sided signs are not permitted if they are abutting a neighboring exhibit, either the back wall or sidewall. If they are free standing or hung in the middle of the exhibit, they are acceptable.

H. Towers:

A free-standing exhibits component that is used only in bulk spaces for identification and display purposes.

Towers are permitted at an overall size of 3'0" x 3'0" (column), and to a maximum height of 16 feet. They may be positioned along space edge(s); however, any additional exhibit structures or components must be set at least 10'0" from tower(s). Exhibitors must have drawings available for submission to NMMA, the installation and dismantling contractor and governmental authority during the time the tower is being erected, exhibited and dismantled at the show site. Drawings must include a signature or stamp of a reviewing structural engineer indicating that the structure design is properly engineered, and a signature of an authorized official of the exhibit building company indicating that the structure is built in compliance with the details and specifications set forth on the drawing.

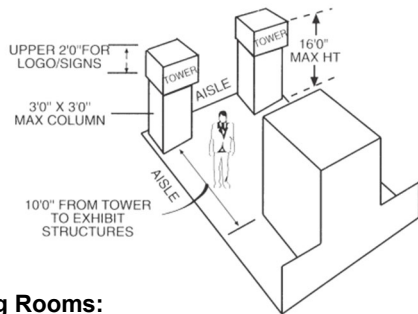

I. Closing Rooms:

Three or four sided exhibit component used to obtain privacy for conferences or business transactions.

STANDARD BOOTH space closing rooms must be at least 10'0" from an adjoining exhibit. Closing room walls will be permitted up to a height of 8'0" with an additional 2'0" for signs/logos. Logos or other graphics may not be placed on walls, so as not to obstruct sight lines. Walls may be solid construction for a height of 4'0" only, the remaining 4'0" must be of a clear Plexiglas (a 10% tint is allowed). Dark or smoked Plexiglas walls are prohibited. BULK space closing rooms (i.e. peninsulas and islands) must conform to the display regulations for these exhibits.

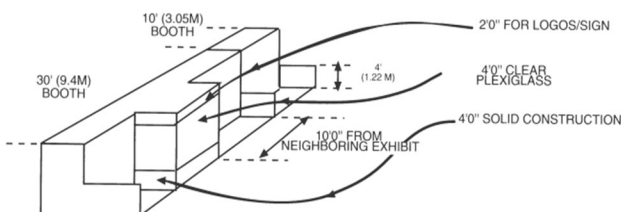

J. Hanging Signs:

An exhibit component suspended above an exhibit (standard booths excepted) for the purpose of displaying graphics or identification.

Hanging signs, banners and graphics are only allowed (building design permitting) over bulk space exhibits (i.e., islands, peninsulas or some perimeter wall exhibits). Hanging signs are prohibited in standard (linear) booth Spaces. Signs may not contain or allude to discounts or prices. Signs in a manufacturer's display will not be permitted to refer to another manufacturer except (with NMMA's approval) for component identification purposes.

Inflatable signs or forced air or helium balloons for identification purposes must be approved in advance by NMMA due to variances in facility requirements. Balloons in outdoor, bulk area exhibits must be securely fastened to the ground or a boat, and positioned so as not to present hazard. Helium balloons are not to be handed out to show visitors.

Size: The physical hanging sign measurement cannot exceed 10'0" in height. The total sign length cannot exceed 50% of the corresponding side dimension of the space. For example, a sign a hung along a 100'0" sideline may not exceed 50'0" in length and 10'0" in height. Horizontal banners must comply with the above limitations. The overall acceptable dimensions for vertical banners are 4'0" x 20'0" (hall construction permitting). This variance is due to the fact that a vertical banner spans a smaller area, and should not hinder viewing other exhibits and signs.

Height: Signs must be hung at a height determined by hall construction. This height limit will be noted in the exhibitor kit.

Placement: Signs are to be positioned so as not to hang over/into neighboring exhibits or aisles.

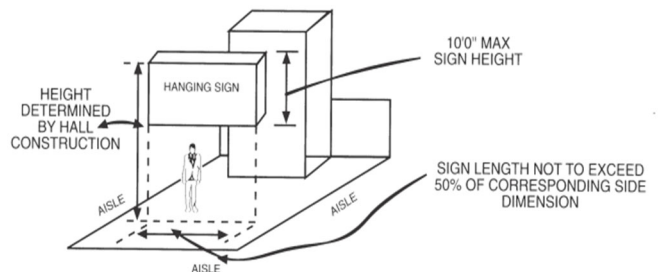

K. Canopies, Umbrellas, Ceilings & Headers:

An exhibit component supported over an exhibitor's space.
Canopies are not allowed in the Louisville Boat, RV & Sportshow.

Height: False ceilings, canopies, headers and umbrellas are permitted to a height that corresponds to the height regulations for the exhibit component of which they are a part; however, that area between 4'0" and 8'0" high must remain open and free of obstruction.

Depth: Canopies may extend out to the aisle line and up to the booth line on either side of an exhibitor's space providing that the support structure will not exceed 3'0" in width when placed within 10 lineal feet of an adjoining exhibit and not confined to that area of the exhibitor's space, which is at least 5'0" from the aisle line.

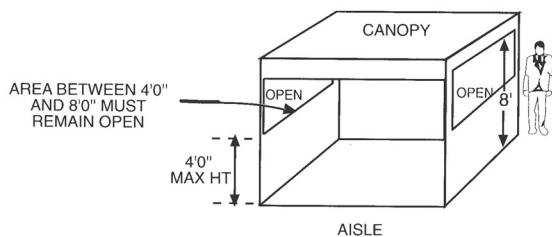

L. Static Displays:

No new-boat displays are permitted in booth areas. Boat manufacturers and dealers may only exhibit in bulk display space, and are prohibited from buying booth space for "static" displays. The following exceptions are allowable:

1. Concepts not yet in production.
2. Brokerage display boards.
3. Boat Builders who are defined as custom builders as determined by NMMA.
4. Sold out shows.

M. Vehicles on Display:

The NMMA Shows Committee policy specifically prohibits any literature, signs, sales staff and financial consideration from the vehicle supplier, manufacturers or their dealers. Any proposal for the display of an automobile, truck, or other vehicle must be presented to NMMA for approval for consideration at least 8 weeks in advance of the show. Some facilities have exclusive sponsorship agreements that may prohibit the display of automotive vehicles.

N. Demonstrations:

Any part of the exhibitor's presentation involving the interaction of exhibit personnel and their audience through demonstrations, corporate presentations, or sampling.

Demonstration areas must be organized within the exhibitor's space so as not to interfere with any aisle traffic. Sampling or demonstration tables must be placed a minimum of 2'0" from the aisle line. Should spectators or samplers interfere with the normal traffic flow in the aisle or overflow into neighboring exhibits, NMMA will have no alternative but to request that the presentation or sampling be stopped or the exhibit rearranged to contain the spectators or samplers within the exhibit space.

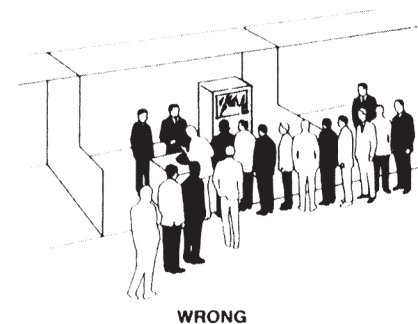
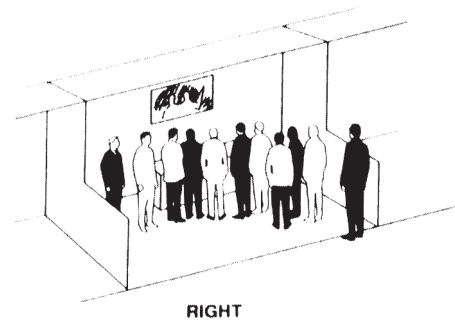

O. On-Site Marketing:

Marketing (advertising, branding, promoting) must be confined to an exhibitor's contracted space. Marketing in common areas including but not limited to interior/exterior walls, doors, stairs, elevators, escalators, aisles, ceilings, restrooms, information booths, literature bins, and concession areas is prohibited unless pre-approval, in writing, is granted by the NMMA. The NMMA reserves the right to revoke this approval at any time.

P. Additional Display Information:

1. If copyrighted music is to be played in display, Exhibitor must obtain all necessary licenses.
2. Any bow thruster features on a boat must be disengaged while on display.
3. Signs used within an exhibit space should be produced in a professional manner.
4. Dimensions of all exhibit area are believed to be accurately stated on the floor plans. If there is a discrepancy or error, NMMA will attempt to correct the situation once it is brought to our attention.
5. Facility lighting may not illuminate all areas evenly and effectively. NMMA assumes no responsibility for providing additional lighting. If available, Exhibitor may order additional lighting at its expense (see Exhibitor Kit).
6. NMMA assumes no responsibility for temperature levels at any time.

Sound: Noise levels from demonstrations or sound systems must be kept to a minimum so as not to interfere with other exhibitors on a continual basis. NMMA will make final decision on volume levels and frequency.

Safety: All product demonstrations involving any moving and potentially hazardous machines, display or parts, must be approved in advance by NMMA at least 45 days in advance of the show opening.

Q. Character of Exhibits:

1. NMMA encourages the use of creative, innovative exhibits; however, NMMA does reserve the right to decline or prohibit any activity, exhibit or component which, in its opinion, is either not suitable or not contractually permitted in the show. This reservation concerns persons, objects, decorations, conduct, printed matter, advertising, souvenirs, catalogues and all other items that affect the character of the show.
2. Exhibits must be set up and staffed during all open hours of the show. Exhibit removal prior to the final day's close of the show is strictly forbidden. Exhibitors that do not comply with these regulations will not be offered renewal of their space in the following year's show.
3. Exhibitors have the right to distribute their catalogues and other approved printed matter (i.e. only information related to items displayed), but only within their space(s), not in the aisles or lobby.
4. Exhibitors are not permitted to use or distribute any sale device(s) which contributes to an annoying atmosphere, some of which may include public address systems, raised dais, stage-type lighting,

flashing lights, beacons, loud machinery, helium balloons, ribbons, inflated signs, alarms, horns, bells (whether part of boat equipment or separate components), etc. If you are considering one of these elements in your exhibit, please contact NMMA for approval.

5. Video or audio equipment is permitted, but must be operated so as not to create a disturbance.
6. Drawings, guessing games and prize contests of any kind sponsored by individual exhibitors are subject to the prior approval of NMMA, and must also adhere to local lottery laws.
7. No alcoholic beverages or food may be served on the show floor without the consent of NMMA and the facility concessionaire.
8. On docks, exhibitors who occupy both sides or a pier's end may dress that area with carpet, banners, or tents, etc. A banner across the pier will not be allowed if there are other exhibits beyond it. Exhibitor may carpet a dock section, or put up a tent if he controls both sides, or if his neighbor across the dock agrees.
9. NMMA will arrange for the sweeping of aisles, but exhibitors must, at their own expense, keep their space clean: boats dusted, carpet vacuumed; and exhibits in good order.
10. Exhibits are required to maintain the nautical or outdoor theme of the show and should be set up in a professional manner so as not to relay a "flea market" atmosphere. Exhibit spaces should be inviting to attendees, free of clutter and garbage. Boxes may not be visibly stored within the display and should be stored under skirted tables or behind partitions.
11. All products offered for display must be deemed acceptable by NMMA. If items for display include both marine product and items that can apply to non-marine use, the boating or outdoor product must be the prominently featured item in the display.

R. AMERICANS WITH DISABILITIES ACT

Exhibitors are responsible for complying with all applicable public accommodations requirements of the Americans with Disabilities Act ("ADA") within their exhibit space including, without limitation: (i) the "readily achievable" removal of physical barriers within Exhibitor's exhibit and exhibit space (to the extent within Exhibitor's control) (e.g., set-up of displays and exhibits in an accessible manner); (ii) the provision of auxiliary aids and services where necessary to ensure effective communication with disabled participants (e.g., Braille or enlarged print handouts, interpreter or simultaneous videotext display); and (iii) any modifications to Exhibitor's exhibit or materials required to enable disabled individuals to participate equally in the Exhibitor's exhibit.

****Partial content borrowed courtesy of the International Association of Exhibition and Events. ****

Chicago
231 S. LaSalle, Suite 2050
Chicago, IL 60604
312.946.6200 Fax: 312.946.0401

Louisville • Nashville
143A Arnold Drive
Shepherdsville, KY 40165
502.957.1666 Fax: 866.590.8907

Miami • Atlanta • Tampa
NMMA – Southern Regional Office
15100 NW 67th Ave, Suite 205
Miami Lakes, FL 33014
954.441.3220 Fax: 866.542.8673

Minneapolis • Northwest
331 2nd Avenue South, Suite 701
Minneapolis, MN 55401
612.332.8330 Fax: 612.827.1424

Atlantic City • New York
Baltimore • Norwalk • New England
330 West 38th Street, Suite 206
New York, NY 10018
646.370.3660 Fax: 888.649.7786

St. Louis • Kansas City
111 N. Taylor Ave., Suite A
Kirkwood, MO 63122
314.821.5400 Fax: 866.521.6015

Schaumburg • Suffern • Edison
750 Central Avenue, Suite R
Dover, NH 03820
603-431-4315 Fax: 603-431-1971